

VBB/VBS Series Ball Valve Assemblies



Application

The VBB and VBS Series valves with SmartX Actuators are 2-Way or 3-Way, 1/2" or 3/4", characterized ball valves. The M3 and M2 SmartX Actuators are direct coupled to the VBB/VBS Series valves and accept two-position, floating or proportional control signals from a DDC system, controller, or thermostat for control of hot or chilled water, or solutions of up to 60% glycol. Typical applications include VAV reheat, fan coil units, hot and chilled water coils in air handling units, heat pumps and unit ventilators.

Features

- Easy product selection — all actuators fit all valve bodies.
- Fast, easy actuator installation — no linkage or tools required.
- Flow characterizing insert provides equal percentage flow characteristic for stable, accurate floating and proportional control.
- ANSI IV seat leakage (0.01%) for both 2-Way and 3-Way valves (A and B port).
- Brass and stainless steel trim models.
- Cvs from 0.3...10.
- Normally open, normally closed, and non-spring return assemblies available.
- Two-position, Floating or Proportional (0...5 Vdc, 0...10 Vdc, 5...10 Vdc, or 4...20 mA dc).
- Proportional actuator is direct or reverse acting.
- RoHS Compliant (VBS Assemblies).
- Reach Compliant.

Applicable Literature

- VBB and VBS Series Two-position Spring-Return Ball Valves Installation Instructions, F-27392.
- VBB and VBS Series Floating Spring Return and Non-spring Return Ball Valves Installation Instructions, F-27393.
- VBB and VBS Series Proportional Spring Return and Non-spring Return Ball Valves Installation Instructions, F-27394.
- VBB and VBS Series Brochure, F-27681.
- EN-205 Water System Guidelines, F-26080.
- EN-206 Guidelines for Powering Multiple Actuators, F-26363.

Specifications

Actuator

Voltage	24 Vac for floating and proportional 100...277 Vac for two position multi-voltage types	
Power Requirements	See Table-1, Table-2, and Table-3.	
Control Signal	2-Position, Floating, or Proportional; half wave rectified power supply	
Timing, Full Open to Full Close	See Table-1, Table-2 and Table-3.	
Manual Operating Lever / Position Indicator	Standard on all models.	
Auxiliary End Switch (optional)	SPST 24 Vac/Vdc, 101 mA...5 A max.	
Materials	Thermoplastic base and cover. Approved for use in air plenums.	
Shipping & Storage Temperature Limit	-40...169 °F (-40...76°C).	
Operating Temperature Limit at max fluid temp.	Floating	32...140 °F (0...60 °C)
	Proportional	32...140 °F (0...60 °C)
	Two-Position	32...169 °F (0...76 °C)
	Humidity	5...95% relative humidity, non-condensing.
Locations	NEMA 2, IEC IP31. Indoor Use Only.	

Valve

Service ^a	Hot and chilled water, up...60% glycol.
System Static Pressure Limit	600 psi (4137 kPa).
Fluid Temperature Limit	20...250°F (-7...121°C).
Cv (Kv)	See Tables 4 through 7.
Close-off Pressure ^b	130 psi 2-Way; 70 psi 3-Way
Differential Pressure	30 psi normal operation 20 psi quiet operation.
Seat Material	PTFE
Characterized Insert	Glass-filled PEEK
Seat Leakage	ANSI class IV (0.01%) at both A and B ports with pressure at inlet.
End Connections	NPT threaded (VBxxNxx)
Rangeability	Greater than 300:1.
Body Material	Forged brass.
Stem Material	Stainless steel anti-blow out stem with dual Viton™ o-rings.
Ball Material	Chrome plated brass (VBB series) or stainless steel (VBS series).

a. Not rated for steam service.

b. Close-off is defined as the maximum allowable pressure drop to which a valve may be subjected while fully closed.

Agency Listings

M2 SmartX actuators	North America: c-UL-us LISTED per UL 873 and C22.2 No.24. European Union: LVD 2006/95/EC and EMC 2004/108/EC directives compliant.
M3 SmartX actuators:	North America: c-UL-us LISTED per UL 60730-1 & -2-14 and CSA E60730-1 & -2-14. FCC part15 classB & ICES-003 classB emissions compliant. European Union: LVD 2014/35/EU and EMC 2014/30/EU directives, per EN 60730-1 & -2-14. EN 61000-6-2 immunity & EN 61000-6-3 emissions compliant.
Australia	This product meets requirements to bear the RCM Mark.
Plenum Rating	Actuators with terminal block or plenum cable leads are plenum rated.
CRN Number	CRN OC0970.9012345678NTY.
RoHS Compliant	VBS valves and M3/M2 actuators comply with European Directive RoHS 2 Directive 2011/65/EU. Please consult factory for part number specific compliance.
REACH Compliant	Compliant as defined in Article 33 of the REACH Regulation (EC)1907/2006.

Application Schematics

Typical applications

For simplicity, balancing valves and control devices are not shown.

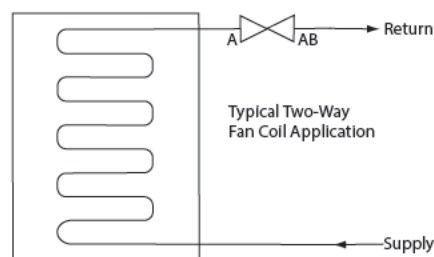

Mixing applications

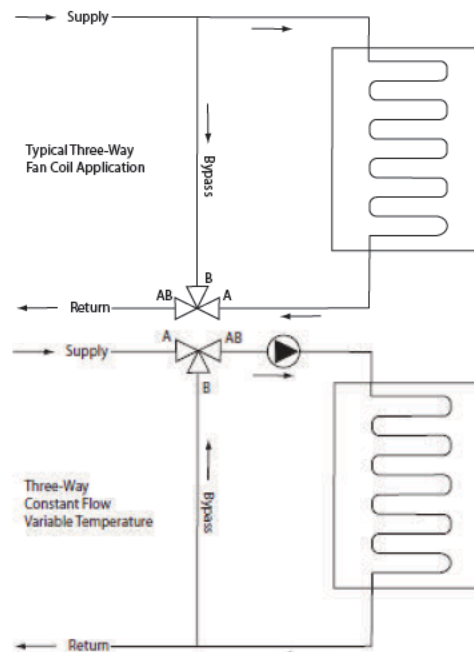

Ball Valve Assembly Selection Procedure

1. Select the actuator. When selecting a ball valve assembly, you must know the control signal type and voltage to first select an actuator. Consult the following tables: Table-1 covers two-position actuator specifications and model numbers, Table-2 covers floating actuator specifications and model numbers and Table-3 covers proportional actuator specifications and model numbers.
2. Select the valve body. The valve body model number is selected based on the line size (1/2" or 3/4"), ball material trim, and flow coefficient (Cv/Kv) required. Consult Table-4 and Table-5 for brass trim valve body specifications and model numbers and Table-6 and Table-7 for stainless steel trim valve body specifications and model numbers. See "Flow Coefficient Selection" for information in determining the flow coefficient.

Other considerations

1. General service conditions: Make sure the actuator is suitable for the anticipated ambient conditions and that the valve body is compatible with the system fluid temperature and pressure requirements.
2. Close-off pressure: Confirm that the VBB/VBS ball valve's close off rating is suitable for the valve control application.
3. Space requirements: If mounting space limitations are a consideration, check the actuator/valve assembly dimensions.
4. Pipe reducers: Refer to Tables for estimating effective Cvs when using pipe reducers.
5. Ordering information. You may order the actuator and valve body separately or as a factory assembly. To order a complete valve and actuator assembly, specify the valve body part number and the actuator part number separated by a "+." Example: To order actuator valve body VBB2N15 and M312A00 as a factory valve/actuator assembly, specify VBB2N15+M312A00.

Flow Direction

A notch cut into the stem indicator at the tip of the valve stem is an external indicator of where the closed portion of the ball sits internally. Check the notch position prior to assembling the actuator to verify the ball is orientated in the correct plane.

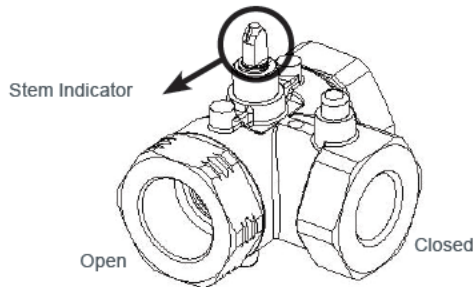

In the drawings below, the black mark on the stem indicator represents this stem notch.

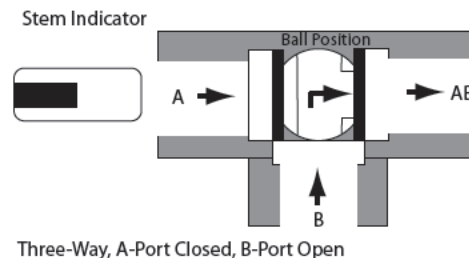
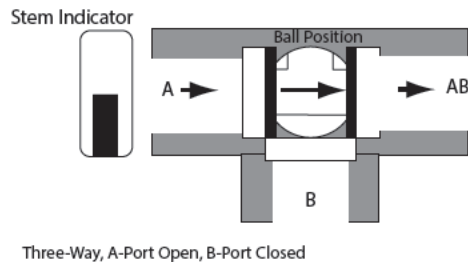
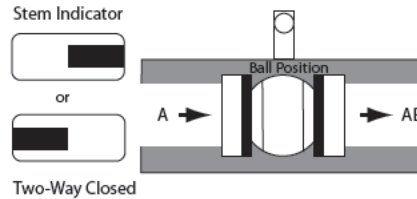
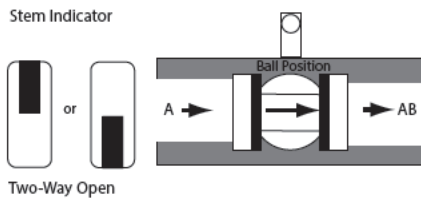

Product Selection: Actuators

Table-1: Two-Position Actuators

Part Number	Control Signal	Spring Return Action (Valve Normal Position)	VA / Voltage	Leads	Stroke Timing ^g	Spring Return Timing ^g	End Switch
M210A00	Two-Position	Normally Open	3.5/1.8 at 24 Vac/24 Vdc	Removeable Terminal Block ^b	50 sec	35 sec.	
M210A01				10 ft. (3.05 m) Plenum Cable ^c			SPST
M210A11							
M210A02				18 in. (45 cm) Appliance Wire			SPST
M210A12							
M210M02				18 in. (45 cm) Appliance Wire			SPST
M210M12		6.0/6.0 at 100...277 Vac, 50/60 Hz					
M220A00		Normally Closed	3.5/1.8 at 24 Vac/24 Vdc	Removeable Terminal Block ^b	50 sec	35 sec.	
M220A01				10 ft. (3.05 m) Plenum Cable ^c			SPST
M220A11							
M220A02				18 in. (45 cm) Appliance Wire			SPST
M220A12							
M220M02	18 in. (45 cm) Appliance Wire			SPST			
M220M12		6.0/6.0 at 100...277 Vac, 50/60 Hz					

Table-2 Floating Actuators

Part Number	Control Signal	Spring Return Action (Valve Normal Position)	VA @ 24 Vac 50/60 Hz	Leads	Stroke Time, sec. 50/60 Hz	Time-out Delay, sec. 50/60 Hz
M332A00	Floating	None	2.3/2.4	Terminal Block ^b	159/135	181 Sec
M332A01				10 ft. (3.05 m) Plenum Cable ^c		
M312A00		Normally Open	3.2/3.3 ^d	Terminal Block ^b		
M312A01				10 ft. (3.05 m) Plenum Cable ^c		
M322A00		Normally Closed	3.2/3.3 ^d	Terminal Block ^b		
M322A01				10 ft. (3.05 m) Plenum Cable ^c		

Table-3 Proportional Actuators

Part Number	Control Signal	Spring Return Action (Valve Normal Position)	VA @ 24 Vac 50/60 Hz	Leads	Stroke Time, sec. 50/60 Hz	Time-out Delay, sec. 50/60 Hz
M333A00	Proportional ^a (Vdc : 0...5, 0...10, 2...10, 5...10, 4...20 mA dc ^e)	None	2.7/2.8	Terminal Block ^b	159/135	200/166
M333A01				10 ft. (3.05 m) Plenum Cable ^c		
M313A00		Normally Open	2.7/2.8 ^d	Terminal Block ^b		
M313A01				10 ft. (3.05 m) Plenum Cable ^c		
M323A00		Normally Closed	2.7/2.8 ^d	Terminal Block ^b		
M323A01				10 ft. (3.05 m) Plenum Cable ^c		

- a. Default configured for 0...10 Vdc input signal, direct acting control.
- b. All terminal block and appliance wire units accept a 1/2" conduit connector fitting (.875" diameter).
- c. All plenum cable units include an integral 3/8" conduit connector fitting.
- d. Size transformer for 10 VA per actuator.
- e. For 4...20 mA control, a separate isolated transformer must be used with each valve.
- g. Nominal.

Product Selection: Brass Trim Valves

Table-4 2-Way Brass Trim Valve Bodies

Size	Part Number	End Connection	Cv (Kv)
1/2"	VBB2N00	NPT	0.3 (0.3)
	VBB2N01		0.7 (0.6)
	VBB2N02		1.2 (1.0)
	VBB2N03		2.1 (1.8)
	VBB2N04		3.5 (3.0)
	VBB2N05		4.7 (4.1)
	VBB2N06		7.7 (6.7)
	VBB2N07 ^b		10 (8.7)
3/4"	VBB2N10		0.3 (0.3)
	VBB2N11		0.7 (0.6)
	VBB2N12		1.2 (1.0)
	VBB2N13		2.1 (1.8)
	VBB2N14		3.5 (3.0)
	VBB2N15		4.7 (4.1)
	VBB2N16		7.7 (6.7)
	VBB2N17 ^b	10 (8.7)	

b. Full Port Model without characterized disc.

Table-5 3-Way Brass Trim Valve Bodies

Size	Part Number	End Connection	Cv (Kv) A Port	Cv (Kv) B Port
1/2"	VBB3N00	NPT	0.3 (0.3)	0.3 (0.3)
	VBB3N01		0.6 (0.5)	0.8 (0.7)
	VBB3N02		1.0 (.85)	0.8 (0.7)
	VBB3N03		2.0 (1.7)	1.5 (1.3)
	VBB3N04		3.0 (2.6)	1.5 (1.3)
	VBB3N05		4.5 (3.9)	2.7 (2.3)
	VBB3N06		7.3 (6.3)	4.1 (3.5)
	VBB3N07 ^b		10.0 (8.7)	4.8 (4.1)
3/4"	VBB3N10		0.3 (0.3)	0.3 (0.3)
	VBB3N11		0.6 (0.5)	0.8 (0.7)
	VBB3N12		1.0 (.85)	0.8 (0.7)
	VBB3N13		2.0 (1.7)	1.5 (1.3)
	VBB3N14		3.0 (2.6)	1.5 (1.3)
	VBB3N15		4.5 (3.9)	2.7 (2.3)
	VBB3N16		7.3 (6.3)	4.1 (3.5)
	VBB3N17 ^b	10.0 (8.7)	4.8 (4.1)	

b. Full Port Model without characterized disc.

Application Note for 2-Way and 3-Way Valves

The VBB/VBS Series Ball Valves are Characterized Control Ball Valves. They are designed so that flow thru the A-port exhibits equal percentage flow. Thus, the A-port is the control port.

In a three-way valve, the B-port is the bypass port. Flow thru the B-port is designed to be less than that of the A-port. In most applications, this reduced flow compensates for the pressure drop that is seen by the coil supplied by the A-port.

Product Selection: Stainless Steel Trim Valves

Table-6 2-Way Stainless Steel Trim Valve Bodies

Size	Part Number	End Connection	Cv (Kv)
1/2"	VBS2N00	NPT	0.3 (0.3)
	VBS2N01		0.7 (0.6)
	VBS2N02		1.2 (1.0)
	VBS2N03		2.1 (1.8)
	VBS2N04		3.5 (3.0)
	VBS2N05		4.7 (4.1)
	VBS2N06		7.7 (6.7)
	VBS2N07 ^b		10 (8.7)
3/4"	VBS2N10		0.3 (0.3)
	VBS2N11		0.7 (0.6)
	VBS2N12		1.2 (1.0)
	VBS2N13		2.1 (1.8)
	VBS2N14		3.5 (3.0)
	VBS2N15		4.7 (4.1)
	VBS2N16		7.7 (6.7)
	VBS2N17 ^b	10 (8.7)	

b. Full Port Model without characterized disc.

Table-7 3-Way Stainless Steel Trim Valve Bodies

Size	Part Number	End Connection	Cv (Kv) A Port	Cv (Kv) B Port
1/2"	VBS3N00	NPT	0.3 (0.3)	0.3 (0.3)
	VBS3N01		0.6 (0.5)	0.8 (0.7)
	VBS3N02		1.0 (.85)	0.8 (0.7)
	VBS3N03		2.0 (1.7)	1.5 (1.3)
	VBS3N04		3.0 (2.6)	1.5 (1.3)
	VBS3N05		4.5 (3.9)	2.7 (2.3)
	VBS3N06		7.3 (6.3)	4.1 (3.5)
	VBS3N07 ^b		10.0 (8.7)	4.8 (4.1)
3/4"	VBS3N10		0.3 (0.3)	0.3 (0.3)
	VBS3N11		0.6 (0.5)	0.8 (0.7)
	VBS3N12		1.0 (.85)	0.8 (0.7)
	VBS3N13		2.0 (1.7)	1.5 (1.3)
	VBS3N14		3.0 (2.6)	1.5 (1.3)
	VBS3N15		4.5 (3.9)	2.7 (2.3)
	VBS3N16		7.3 (6.3)	4.1 (3.5)
	VBS3N17 ^b	10.0 (8.7)	4.8 (4.1)	

b. Full Port Model without characterized disc.

Application Notes

The VBB/VBS Series Ball Valves are valve actuator assemblies designed to make incremental adjustments to flow based on the control signal input. The actuators are not intended for continuous use in zero dead band control systems.

Two-Position Spring Return SmartX Actuators

When powered, the actuator moves to the desired position, winding the spring return system. When power is removed, the spring returns the actuator to the normal position. Two-position spring return actuators can be purchased with an optional built-in auxiliary SPST end switch for interfacing or signaling; for example, zone pump burner control.

Floating/Proportional Spring Return SmartX Actuators

When power is applied to the actuator, there is a 3-second delay before the solenoid latches and the gear train is engaged. Upon power loss, the solenoid releases after 2 seconds, allowing the actuator to spring return to normal position. This prevents the loss of valve position during brief outages. The spring return feature should not be used for routine, normal operation.

Proportional Spring Return and Non-Spring Return SmartX Actuators

The control signal input and action is selected by means of the input signal dip switch on the actuator circuit board.

All actuators are shipped with the input signal dip switch (SW1) set to ON for a 0...10 Vdc control signal and the remaining dip switches and the control action dip switch set to OFF for direct action (DA; valves opens with increasing control signal, as shown). When using a 4...20 mA dc control signal, a separate isolation transformer must be used with each actuator.

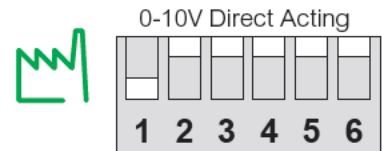

When using switches 1-4, the lowest numbered dip switch set to ON takes priority, e.g. if both SW2 and SW4 are on, SW2 takes precedent. SW1 through SW4 must be OFF (and SW5 ON) for 4-20 mA mode. For more information see Guidelines for Powering Multiple Actuators EN-206 (F-26363).

Multiple actuators may be connected to a single controller. Do not exceed the maximum current draw of the controller or transformer.

Proportional Actuators perform a self-calibration cycle on power-up. The actuator will run to the open direction for approximately 20 seconds and then to the closed direction for approximately 2 ½ min (60 Hz) or 3 ½ min (50Hz). See Table-2 for exact timing. Once this cycle is complete, the actuator will then accept and respond to the control signal.

Do not use manual positioning while power is applied to the actuator. Manual positioning of the actuator while power is applied is NOT recommended. If the actuator is manually positioned while power is applied, the calibration cycle will need to be completed again for the actuator to function properly. To recalibrate the actuator, cycle power off for more than 6 seconds.

Floating Spring Return and Non-Spring Return SmartX Actuators

Spring Return and Non-Spring Return actuators with time-out will automatically limit the running time of the actuator. The time-out feature automatically cuts off the control signal to the valve after three minutes (see Table-1) of continuous operation. Upon change in control signal direction, the actuator will resume operation. The controller or thermostat used to operate the Non-Spring Return Floating actuator without timeout must be configured to turn off the control signal after being continuously on for three minutes. Multiple actuators may be connected to a single controller. Do not exceed the maximum current draw of the controller or transformer.

Power/Failure Action

	Control Signal	Position upon loss of power		
		Non-Spring Return Actuator	Spring Return Open Actuator - Fail Open	Spring Return Closed Actuator - Fail Closed
Floating	Power to "Open" terminal will open A to AB	Maintain last position	Will spring A to AB open	Will spring A to AB closed
Proportional	DA Dip Switch selected (SW6 OFF)- Increase in control signal will open A to AB	Maintain last position	Will spring A to AB open	Will spring A to AB closed
	RA Dip Switch selected (SW6 ON)- increase in control signal will close A to AB	Maintain last position	Will spring A to AB open	Will spring A to AB closed
2-Position	Control Signal	Spring Return Open Actuator	Spring Return Closed Actuator	
	Power On	A to AB Closed	A to AB Open	
	Power Off	A to AB Open	A to AB Closed	

Note: 2-Way valve operation described. For a 3-Way valve, A to AB operation is the same. B to AB operation is opposite that of A to AB operation.

Dimensions

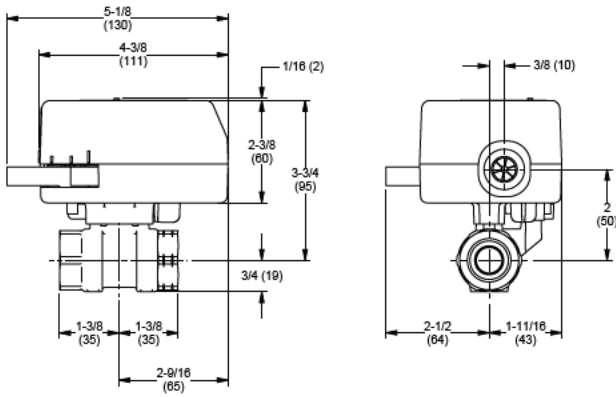

2-Way Spring Return Two Position Assembly Shipping Weight: 2.8 lbs (1270 g)

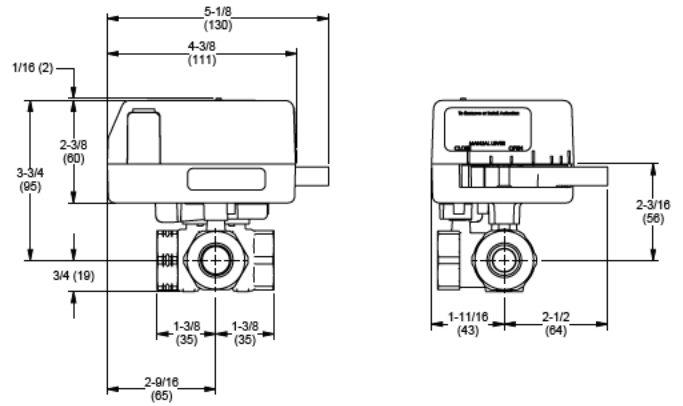

3-Way Spring Return Two Position Assembly Shipping Weight: 3.0 lbs (1360 g)

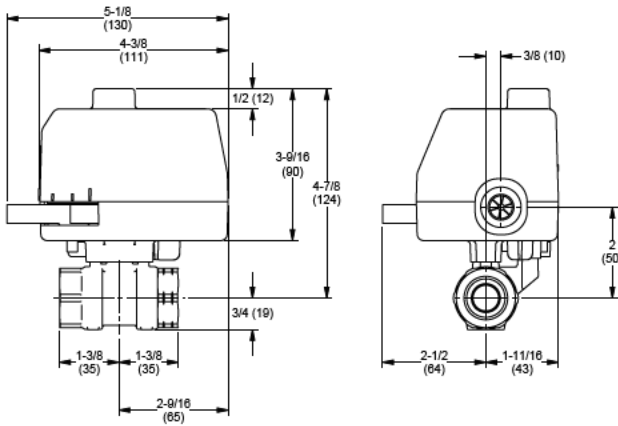

2-Way Floating/Proportional Non-Spring Return Assembly Shipping Weight: 2.2 lbs (998 g)

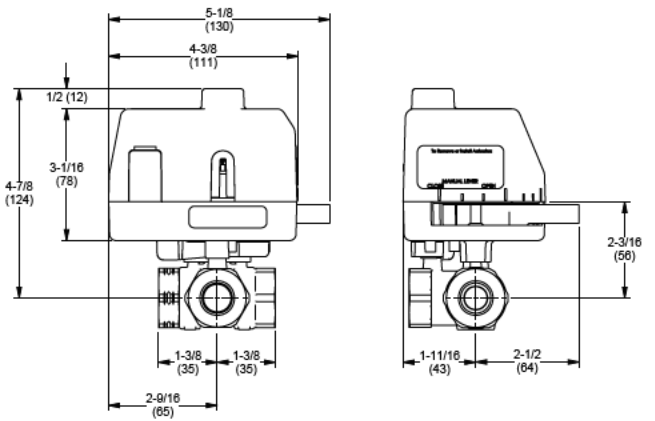

3-Way Floating/Proportional Non-Spring Return Assembly Shipping Weight: 2.4 lbs (1089 g)

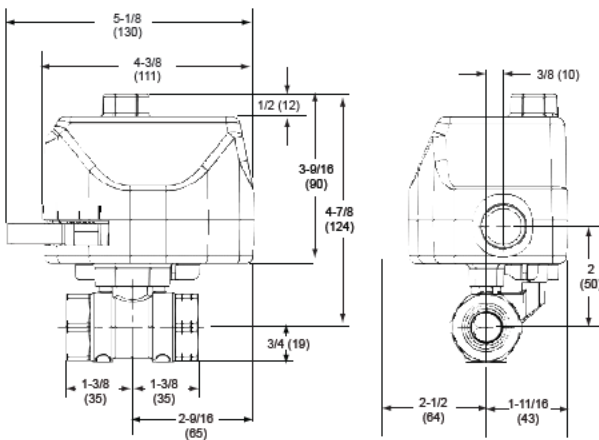

2-Way Spring Return Floating/Proportional Spring Return Assembly Shipping Weight: 2.4 lbs (1089 g)

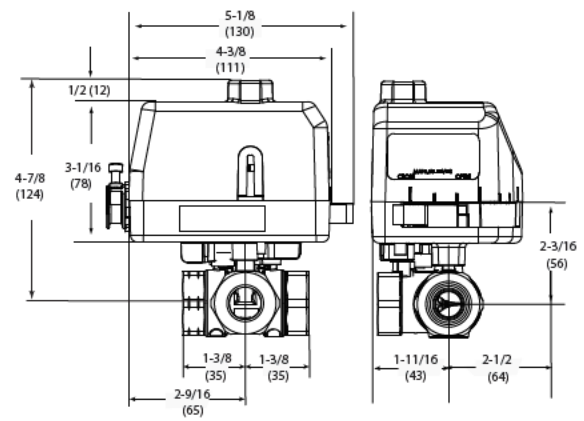

3-Way Floating/Proportional Spring Return Assembly Shipping Weight: 2.6 lbs (1180 g)

All dimensions shown are rounded to the nearest 1/16". An additional 1 inch is required to remove the actuator from the valve.

Cavitation Limits On Valve Pressure Drop

A valve selected with too high a pressure drop can cause erosion and/or wire drawing of the flow characterizing insert. In addition, cavitation can cause noise, damage to the valve trim (and possibly the body), and choke the flow through the valve.

A valve selected with too high a pressure drop can cause erosion of seals and/or wire drawing of the seat. In addition, can cause noise, damage to the valve trim (and possibly the body), and choke the flow. Do not exceed the maximum differential pressure (pressure drop) for the valve selected. The following formula can be used on higher temperature water systems, where cavitation could be a problem, to estimate the maximum allowable pressure drop across the valve:

$$P_m = 0.5 (P_1 - P_v)$$

Where:

- P_m = Maximum allowable pressure drop (psi)
- P_1 = Absolute inlet pressure (psia)
- P_v = Absolute vapor pressure (psia)

Note: Add 14.7 psi to gauge supply pressure to obtain absolute pressure value.

For example, if a valve is controlling 200°F water at an inlet pressure of 18 psig, the maximum pressure drop allowable would be:

$$P_m = 0.5 [(18 + 14.7) - 11.53] = 10.6 \text{ psi}$$

(Vapor pressure of 200°F water is 11.53 psia)

Systems where cavitation is shown to be a problem can sometimes be adjusted to provide higher downstream back pressures. Valves having harder seat materials should be furnished if velocities are excessive.

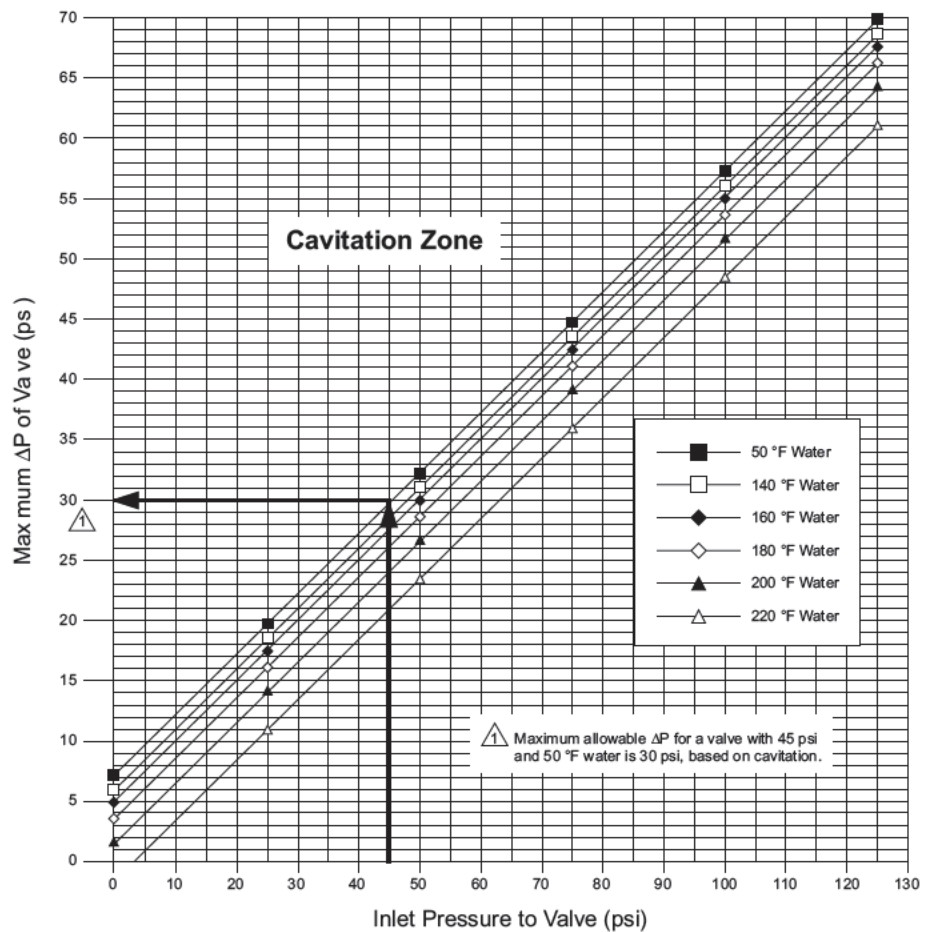

Pressure Drop Selection

Modulating control valves are usually selected to take a pressure drop of at least 50% of the “available pressure.” As “available pressure” is often difficult to calculate, the normal procedure is to select a valve using a pressure drop at least equal to that in the coil or other load being controlled (except where small booster pumps are used) with a minimum pressure drop of at least 5 psi (34 kPa). When the design temperature drop is less than 60°F (33°C) for conventional heating systems, higher pressure drops across the valve are needed for good results (see below).

Pressure Drop

Design Temperature Load Drop °F (°C)	Recommended Pressure Drop (% of available pressure)	Multplier on Load Drop
60 (33) or more	50%	1 x Load Drop
40 (22)	69%	2 x Load Drop
20 (11)	70%	3 x Load Drop

Flow Coefficient Selection

When sizing a valve, you must select a flow coefficient (Cv), which is defined as the flow rate in U. S. gallons per minute (GPM) of 60 °F water that will pass through a fully open valve with 1 psi pressure drop (Δp ; $k_v = m^3/h$ with a 1 bar ΔP). It is calculated using the formula:

$$C_v = GPM / (\sqrt{\Delta P}) \quad (\Delta P \text{ is in psi}) \quad \text{or} \quad K_v = (m^3/h) / (\sqrt{\Delta P}) \quad (\Delta P \text{ is in bar})$$

Since the flow rate through the heat exchanger is usually specified, the only variable normally available in sizing a valve is the pressure drop. The following information can be used to determine what pressure drop to use in calculating a valve Cv. Once you have determined the Cv, consult Table-4, Table-5, Table-6 and Table-7 to select the valve body having the nearest Cv.

Two and 3-Way Valve GPM Table

Valve Differential Pressure (ΔP)	Both	3-Way	2-Way	3-Way	2-Way	3-Way	2-Way	3-Way	2-Way	3-Way	2-Way	3-Way	2-Way	Both
	0.3 Cv	0.6 Cv	0.7 Cv	1.0 Cv	1.2 Cv	2.0 Cv	2.1 Cv	3.0 Cv	3.5 Cv	4.5 Cv	4.7 Cv	7.3 Cv	7.7 Cv	10 Cv
0.5 psi	0.2	0.4	0.5	0.7	0.8	1.4	1.5	2.1	2.5	3.2	3.3	5.2	5.4	7.1
1 psi	0.3	0.6	0.7	1.0	1.2	2.0	2.1	3.0	3.5	4.5	4.7	7.3	7.7	10.0
2 psi	0.4	0.9	1.0	1.4	1.7	2.8	3.0	4.2	4.9	6.4	6.6	10.3	10.9	14.1
3 psi	0.5	1.1	1.2	1.7	2.1	3.5	3.6	5.2	6.1	7.8	8.1	12.6	13.3	17.3
4 psi	0.6	1.3	1.4	2.0	2.4	4.0	4.2	6.0	7.0	9.0	9.4	14.6	15.4	20.0
5 psi	0.67	1.5	1.6	2.2	2.7	4.5	4.7	6.7	7.8	10.1	10.5	16.3	17.2	22.4
6 psi	0.7	1.6	1.7	2.4	2.9	4.9	5.1	7.3	8.6	11.0	11.5	17.9	18.9	24.5
7 psi	0.8	1.8	1.9	2.6	3.2	5.3	5.6	7.9	9.3	11.9	12.4	19.3	20.4	26.5
8 psi	0.85	1.9	2.0	2.8	3.4	5.7	5.9	8.5	9.9	12.7	13.3	20.6	21.8	28.3
9 psi	0.9	2.0	2.1	3.0	3.6	6.0	6.3	9.0	10.5	13.5	14.1	21.9	23.1	30.0
10 psi	0.95	2.1	2.2	3.2	3.8	6.3	6.6	9.5	11.1	14.2	14.9	23.1	24.3	31.6

Flow Characteristics

The VBB/VBS series two- and three-way ball valve assemblies provide equal percentage flow, which is achieved with a flow characterizing insert. The parabolic shape of the orifice allows a gradual change in flow, so that equal movements of the valve stem, at any point of the flow range, change the existing flow an equal percentage, regardless of the flow rate. As shown in the graph to the right a ball valve equipped with the flow insert mirrors the flow characteristic of the coil, resulting in linear heat transfer.

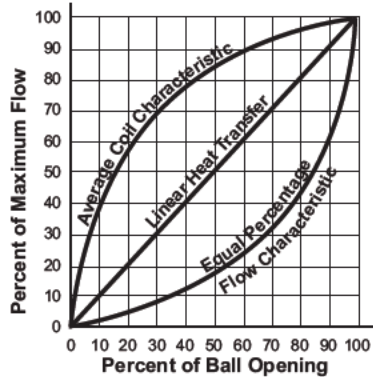
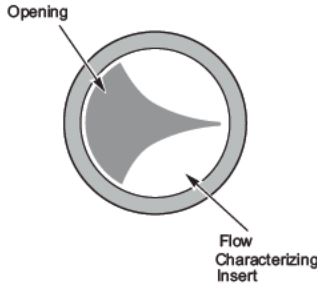

Using Pipe Reducers with Ball Valves

This table provides estimated effective Cvs when using pipe reducers with ball valve assemblies. Use these estimated effective Cvs in place of the rated Cvs when reducers or increasers are located within 6 pipe diameters upstream and 3 pipe diameters downstream of the valve.

▲ WARNING
RISK OF PIPE FAILURE
• Do not use a valve sized less than one half the pipe run size. Erosion or wire draw may cause pipe failure in the reduction area.
Failure to follow this instruction may result in death or serious injury.

2-Way Valves

Valve Size Inch	Valve Body NPT Threaded	Cv (Kv)	Estimated Effective Cv (Kv)						
			Pipe Size In Inches						
			1/2	3/4	1	1-1/4	1-1/2		
1/2	VBx2N00	0.3 (0.3)	0.3 (0.3)	0.3 (0.3)	0.3 (0.3)	-	-		
	VBx2N01	0.7 (0.6)	0.7 (0.6)	0.7 (0.6)	0.7 (0.6)				
	VBx2N02	1.2 (1.0)	1.2 (1.0)	1.2 (1.0)	1.2 (1.0)				
	VBx2N03	2.1 (1.8)	2.1 (1.8)	2.1 (1.8)	2.1 (1.8)				
	VBx2N04	3.5 (3.0)	3.5 (3.0)	3.3 (2.8)	3.1 (2.7)				
	VBx2N05	4.7 (4.1)	4.7 (4.1)	4.4 (3.8)	4.1 (3.5)				
	VBx2N06	7.7 (6.7)	7.7 (6.7)	6.6 (5.7)	5.5 (4.8)				
3/4	VBx2N07	10 (8.7)	10 (8.7)	8.5 (7.4)	7.0 (6.0)	-	-		
	VBx2N10	0.3 (0.3)	-	0.3 (0.3)	0.3 (0.3)			0.3 (0.3)	0.3 (0.3)
	VBx2N11	0.7 (0.6)		0.7 (0.6)	0.7 (0.6)			0.7 (0.6)	
	VBx2N12	1.2 (1.0)		1.2 (1.0)	1.2 (1.0)			1.2 (1.0)	
	VBx2N13	2.1 (1.8)		2.1 (1.8)	2.1 (1.8)			2.1 (1.8)	
	VBx2N14	3.5 (3.0)		3.5 (3.0)	3.5 (3.0)			3.5 (3.0)	
	VBx2N15	4.7 (4.1)		4.7 (4.1)	4.6 (4.0)			4.5 (3.9)	
	VBx2N16	7.7 (6.7)		7.7 (6.7)	7.5 (6.5)			7.3 (6.3)	
VBx2N17	10 (8.7)	10 (8.7)		9.5 (8.2)	9.0 (7.8)	7.2 (6.2)			

3-Way Valves

Valve Size In	Valve Body NPT Threaded	Cv (Kv)	Estimated Effective Cv (Kv)						
			Pipe Size In Inches						
			1/2	3/4	1	1-1/4	1-1/2		
1/2	VBx3N00	0.3 (0.3)	0.3 (0.3)	0.3 (0.3)	0.3 (0.3)	-	-		
	VBx3N01	0.6 (0.5)	0.6 (0.5)	0.6 (0.5)	0.6 (0.5)				
	VBx3N02	1.0 (.9)	1.0 (.9)	1.0 (.9)	1.0 (.9)				
	VBx3N03	2.0 (1.7)	2.0 (1.7)	2.0 (1.7)	2.0 (1.7)				
	VBx3N04	3.0 (2.6)	3.0 (2.6)	2.9 (2.5)	2.8 (2.4)				
	VBx3N05	4.5 (3.8)	4.5 (3.8)	4.2 (3.6)	3.9 (3.3)				
	VBx3N06	7.3 (6.2)	7.3 (6.2)	6.2 (5.3)	5.1 (4.4)				
3/4	VBx3N07	10.0 (8.5)	10.0 (8.5)	8.5 (7.4)	7.0 (6.0)	-	-		
	VBx3N10	0.3 (0.3)	-	0.3 (0.3)	0.3 (0.3)			0.3 (0.3)	0.3 (0.3)
	VBx3N11	0.6 (0.5)		0.6 (0.5)	0.6 (0.5)			0.6 (0.5)	
	VBx3N12	1.0 (.9)		1.0 (.85)	1.0 (.85)			1.0 (.9)	
	VBx3N13	2.0 (1.7)		2.0 (1.7)	2.0 (1.7)			2.0 (1.7)	
	VBx3N14	3.0 (2.6)		3.0 (2.6)	3.0 (2.6)			2.9 (2.5)	
	VBx3N15	4.5 (3.8)		4.5 (3.8)	4.4 (3.8)			4.3 (3.7)	
	VBx3N16	7.3 (6.2)		7.3 (6.2)	7.1 (6.1)			6.9 (5.9)	
VBx3N17	10.0 (8.5)	10.0 (8.5)		9.5 (8.2)	9.0 (7.8)	7.2 (6.2)			

Water System Maintenance

All heating and cooling systems are susceptible to valve and system problems caused by improper water treatment and system storage procedures. The following guidelines are to help avoid valve and water system problems resulting from improperly treated water or storage procedures, and to obtain maximum life from the valves.

1. To maintain non-damaging conditions, clean the system prior to start up. Use a nitrite or molybdate-based treatment program.
2. Use filtration equipment where needed. Properly store off-line systems and monitor water treatment results using corrosion test coupons.
3. Durability of valve stems, balls, seats, and packing is dependent on maintaining non-damaging water conditions.
4. Inadequate water treatment or filtration, not in accordance with chemical supplier/ASHRAE handbook recommendations, can result in corrosion, scale, and abrasive particle formation. Scale and particulates can result in stem and packing scratches, and can adversely affect packing life and other parts of the hydronic system.
5. Follow the advice of a water treatment professional. Consult EN-205 Water and Steam System Guidelines, Engineering Information, F-26080, for further details.

Piping

These valves must be piped so the flow is in the direction of the diagrams below. Flow is from A (and/or B) to AB.

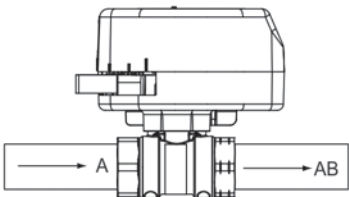

2-Way Valve: Flow A to AB Actuator M313A0x or M323A0x (spring return)

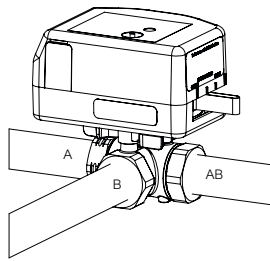

3-Way Valve: Mixing Only A and/or B to AB. Actuator M333A0x (non-spring return)

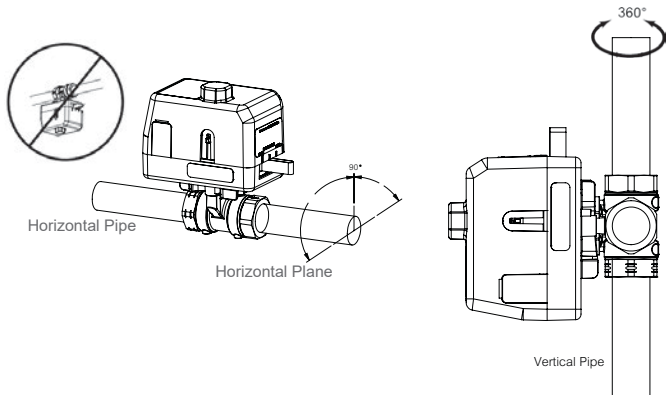

Maintenance

The ball valve assembly itself requires no maintenance. The stem and packing design eliminates the need for packing adjustment for the life of the valve. However, regular maintenance of the total heating and cooling system is recommended to provide sustained optimum performance.

Field Repair

Neither valve nor actuator are field repairable. Replace entire unit as necessary.

Patents

US Patents for VBB/VBS Series Valves and M3/M2 Series Actuators: 5815365, 6044857, 6073907, 7111643, 7131635, 7367544, 7559531. Other US and foreign patents pending.

Mounting

The valves can be mounted in horizontal or vertical piping. When installed in horizontal piping, the actuator must be above the valve body. When installed in horizontal piping the actuator can be tilted left or right but it must not be tilted below 90° from vertical.